



Electronic Temperature Transmitter with HSI Sensor Recognition ETS 4178-H

Description:

The electronic temperature transmitter ETS 4178-H with HSI sensor recognition has been specially developed for use in conjunction with HYDAC measuring instruments HMG 500, HMG 510, HMG 3000, HMG 3010 and CMU 1000.

For data transmission, the ETS 4178-H has an HSI interface (HYDAC Sensor Interface). The HSI sensors are automatically recognized by the above-mentioned HYDAC measuring instruments and all necessary basic settings are taken from each sensor.

Like all temperature transmitters of the ETS 4000 series, the ETS 4178-H features a robust design and excellent EMC properties. Based on corresponding evaluation electronics, the temperature sensor is designed to measure temperatures in the range $-25\text{ }^{\circ}\text{C}$ to $+100\text{ }^{\circ}\text{C}$ ($-13\text{ }^{\circ}\text{F}$ to $212\text{ }^{\circ}\text{F}$).

Special features:

- Fully automatic sensor recognition by, and voltage supply from, HYDAC measuring instruments HMG 500, HMG 510, HMG 3000, HMG 3010 and CMU 1000
- Automatic transfer of measuring range, measured value and measurement unit
- Accuracy $\leq \pm 0.8\%$ FS
- Robust design
- Excellent EMC characteristics
- Excellent long term stability
- Standard protection class IP 67

Technical data:

Input data	
Measuring principle	PT 1000
Measuring range	$-13\text{ }^{\circ}\text{F} \dots 212\text{ }^{\circ}\text{F}$ ($-25\text{ }^{\circ}\text{C} \dots +100\text{ }^{\circ}\text{C}$)
Probe length	6 mm
Probe diameter	4.5 mm
Pressure resistance	8700 psi
Overload pressure	13050 psi
Mechanical connection	SAE 6 9/16-18 UNF 2A
Torque value	15 lb-ft (20 Nm)
Parts in contact with medium ¹⁾	Mech. conn.: Stainless steel Seal: FPM
Output data	
Output signal	HSI (HYDAC Sensor Interface) Automatic sensor recognition through HMG
Accuracy (at room temperature)	$\leq \pm 0.4\%$ FS typ. $\leq \pm 0.8\%$ FS max.
Temperature drift (environment)	$\leq \pm 0.006\%$ FS/ $^{\circ}\text{F}$ typ.
Rise time to DIN EN 60751	t_{50} : ~ 4 s t_{90} : ~ 8 s
Environmental conditions	
Operating temperature range ²⁾	$-40 \dots +185\text{ }^{\circ}\text{F}$ / $-13 \dots +185\text{ }^{\circ}\text{C}$
Storage temperature range	$-40 \dots +212\text{ }^{\circ}\text{F}$
Fluid temperature range ²⁾	$-40 \dots +257\text{ }^{\circ}\text{F}$ / $-13 \dots +257\text{ }^{\circ}\text{C}$
CE mark	EN 61000-6-1 / 2 / 3 / 4
Vibration resistance to DIN EN 60068-2-6 at 10 .. 500 Hz	≤ 25 g
Protection class to IEC 60529	IP 67 (when an IP 67 connector is used)
Other data	
Electrical connection	M12x1, 5 pole
Voltage supply	via HYDAC measuring instruments HMG 500, HMG 510, HMG 3000, HMG 3010 or CMU
Weight	~ 200 g

Note: Reverse polarity protection of the supply voltage, excess voltage, override and short circuit protection are provided.

FS (Full Scale) = relative to complete measuring range

¹⁾ Other seal materials available on request

²⁾ $-13\text{ }^{\circ}\text{F}$ with FPM seal, $-40\text{ }^{\circ}\text{F}$ on request

Model code:

ETS 4 1 7 8 - H - 006 - 000

Mechanical connection

7 = SAE 6, 9/16-18 UNF 2A male

Electrical connection

8 = Male, M12x1, 5 pole
(connector not supplied)

Signal

H = HSI (automatic sensor recognition)

Probe length

006 = 6 mm

Modification number

000 = Standard

Accessories:

Appropriate accessories, such as electrical connectors, can be found in the Accessories brochure.

Note:

The information in this brochure relates to the operating conditions and applications described.

For applications or operating conditions not described, please contact the relevant technical department.

Subject to technical modifications.

For European mechanical connection see European Catalog

Dimensions:

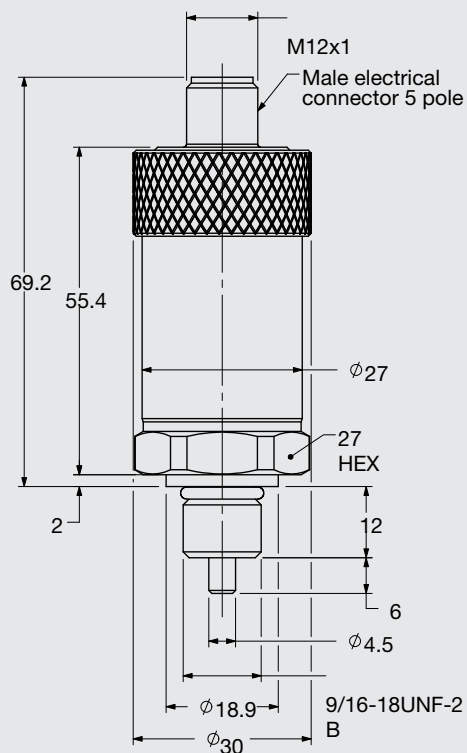

HYDAC ELECTRONICS

90 Southland Dr. Bethlehem, PA 18017
Telephone +1 (610) 266-0100
E-mail: electronics@hydacusa.com
Website: www.hydacusa.com